

ARPL-0.5W Red

FEATURES

- Long operating life
- Highest flux
- Available in Red
- Lambertian radiation pattern
- More energy efficient than incandescent and most halogen lamps
- Low voltage DC operated
- Cool beam, safe to the touch
- Instant light (less than 100ns)
- Fully dimmable
- No UV
- Superior ESD protection
- Eutectic die bonding
- RoHS compliant



APPLICATIONS

- Reading lights (car, bus, aircraft)
- LCD Backlights/light Guides
- Fiber optic alternative/ Decorative / Entertainment
- Mini-accent/Up lighters/Down lighters/ Orientation
- Indoor/Outdoor commercial and Residential
- Architectural
- Cove/Under shelf/Task
- Bollards/Security/Garden
- Portable (flashlight, bicycle)
- Edge-lit signs (Exit, point of sale)
- Automotive Exit (Stop-Tail-Turn, CHMSL, Mirror Side Repeat)
- Traffic signaling / Beacons / Rail Crossing and Wayside

PACKAGE DIMENSIONS

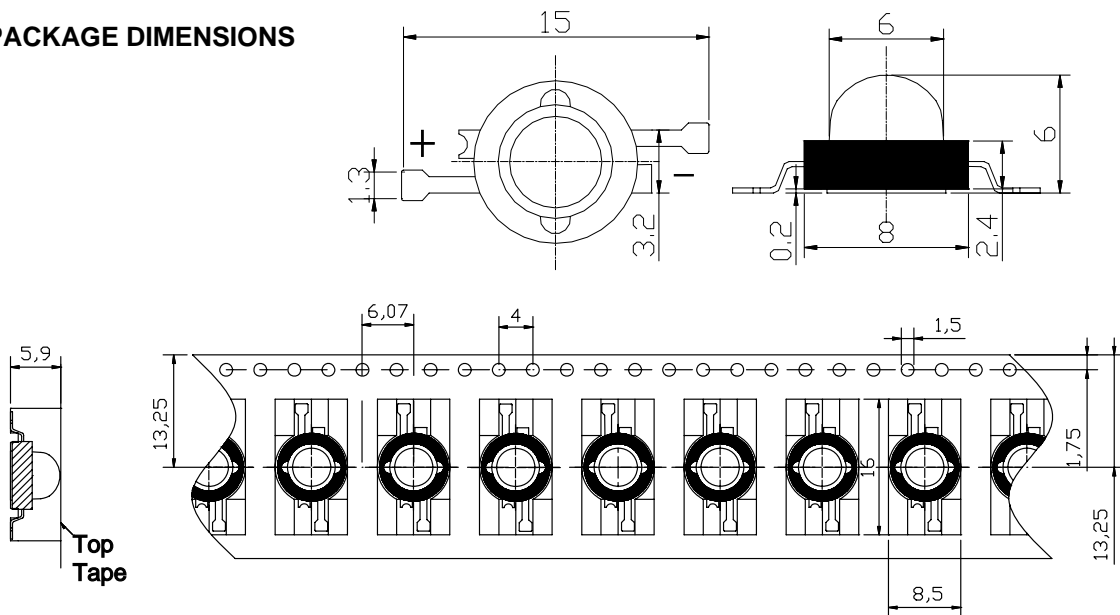

RADIATION PATTERN

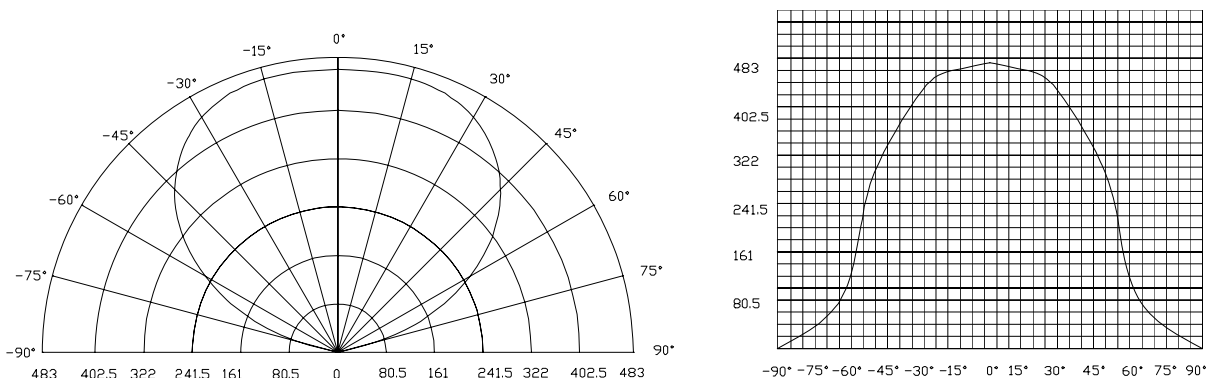

Typical Optical/ Electrical Characteristics @T_j=25°C

Parameter	Symbol	Condition	Min.	Typ.	Max.	Unit
Forward Voltage	V _F	I _F =150mA	2.0	---	2.8	V
Reverse Current	I _R	V _R =5V	---	---	50	μA
50% Power Angle	2θ _{1/2}	I _F =150mA	110	---	140	deg
Luminous Intensity	I _v	I _F =150mA	8.2	---	23.5	lm
Recommend Forward Current	L _F	---	---	150	---	mA
Wave Length	T _c	I _F =150mA	615	---	625	k
Thermal Resistance, Junction to Case	R _{JP}	I _F =150mA	---	10	---	°C/W

Absolute Maximum Rating

Item	Symbol	Absolute Maximum Rating	Unit
Forward Current	L _F	150	mA
Peak Forward Current*	L _{FR}	200	mA
Reverse Voltage	V _R	5	V
Power Dissipation	P _D	500	mW
Electrostatic discharge	E _{SD}	± 4500	V
Operation Temperature	T _{OPR}	-40~+80	°C
Storage Temperature	T _{STG}	-40~+100	°C
Lead Soldering Temperature*	T _{SOL}	Max. 260°C for 3sec Max.	

Note:

*IFP Conditions : Pulse Width≤10msec duty≤1/10

* Our MCPCB is usual use for installation and connection during application, but the ability of heat dissipation is not enough. If lighted, our high power stars will need better another type heat dissipation equipment. So we recommend the working time is not over 5-10 seconds without any heat dissipation equipment.

*Re-flow,wave peak and soak-stannumsoldering etc.is not suitable for this products.

*Suggest to solder it by professional high power LED soldering machine.

*Can use invariable-temperature searing-iron with soldering condition :≤260 degree less than 3 seconds.

TYPICAL ELECTRO-OPTICAL CHARACTERISTICS CURVES

